

FGP-02

PORTABLE OR PENDANT INSULATED CONTROL STATION

Features:

- Configured to your requirements
- Control station excepts (2) VCSO 2 axis joysticks and (4) IEC Pilot devices.
- Reinforced polyester fiberglass construction
- NEMA 4 – IP54 weatherproof sealing
- Protective side and bottom rubber bumpers
- Safety guard bars to prevent inadvertent operation.
- Universal strain relief to accommodate different cable diameters.
- Furnished with steel hanger eyelets
- Light weight 6 – 9 pounds depending on equipment installed
- Optional: Shoulder strap



FGP-02 Dimensions

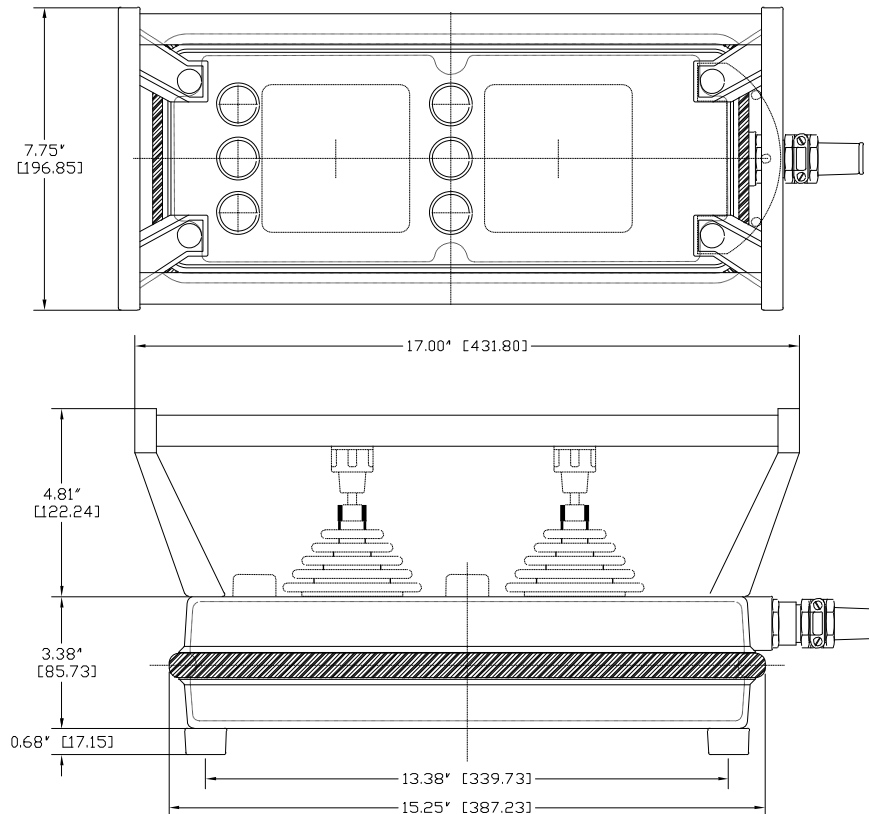

J.R. MERRITT 
CONTROLS, INC.

Stratford, CT • 1-800-333-JRMC • www.jrmerritt.com

Pub. # 40.L9

811