

Dimensions with standard handle G57-12

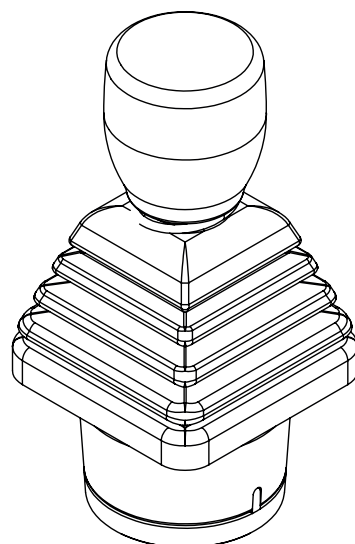
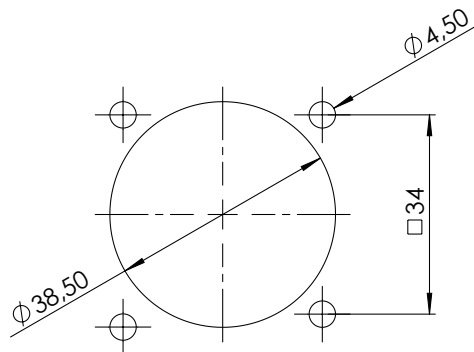
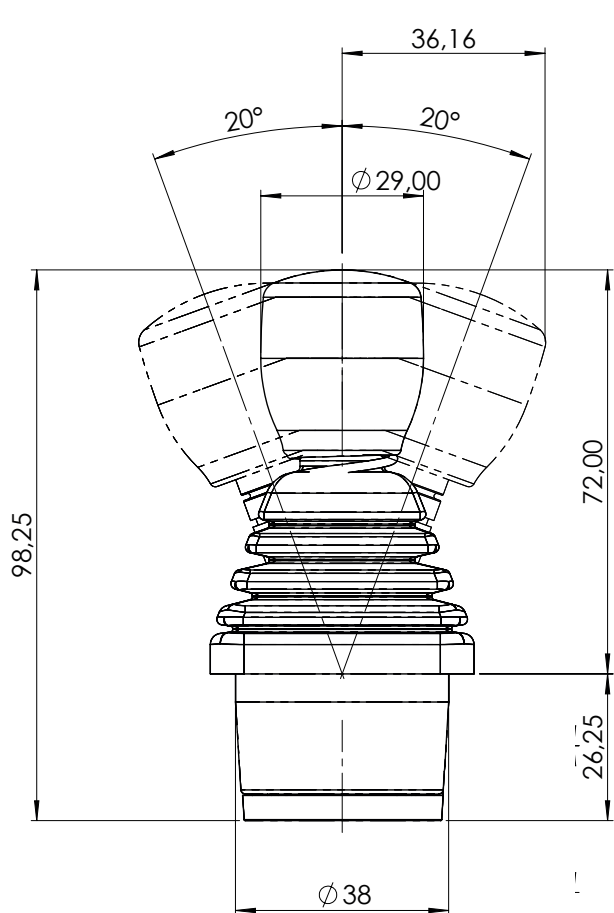

Type code:

		E	Y	A1	
	HS0	V	X	R	A2
Type	_____	_____	_____	_____	_____
Drive	_____	_____	_____	_____	_____
Arrangement	_____	_____	_____	_____	_____
Spring return	_____	_____	_____	_____	_____
Output signal	_____	_____	_____	_____	_____
Handle	_____	_____	_____	_____	G57-12