

Grammer Actimo M

Standard Operating Instructions



IMPORTANT:

Read and understand this Grammer seat instruction manual before operating

- For control system adjustments see enclosed instructions
- Adjust the suspension to accommodate your weight before operating
- If equipped with seat restraint, insure it is fastened before operating
- Adjust the seat and seat system to your personal comfort preference before operating
- Do not adjust seat or seat system while operating this equipment
- Immediately report any malfunction or concern about the seat /seat system to your supervisor
- Under no conditions should you operate equipment that is in disrepair or malfunctioning



IMPORTANT!

Seating and Seat System Disclaimer can be found on our website at:

www.jrmerritt.com/seatdisclaimer



Distributors for Grammer, Inc.

Stratford, CT • www.jrmerritt.com
203-381-0100 • Fax: 203-381-0400

GRAMMER AG: *Seating comfort for high demands!*

*You have acquired a **GRAMMER** seat. Congratulations!*

Take your seat please, and enjoy the ultimate in seating comfort and safety. You will be enjoying a driver's seat characterized by user-friendliness and a high degree of adaptability.

With your new seat you are not only preserving your health; you are improving your performance and efficiency as well.

*Have a good trip, with best wishes from
your **GRAMMER** Team*

Imprint

Copyright © **GRAMMER** AG

GRAMMER AG
Postfach 1454
D-92204 Amberg

Reprinting, reproduction or translation,
in whole or in part, requires the written
permission of the **GRAMMER** AG

Amberg, 11/2005



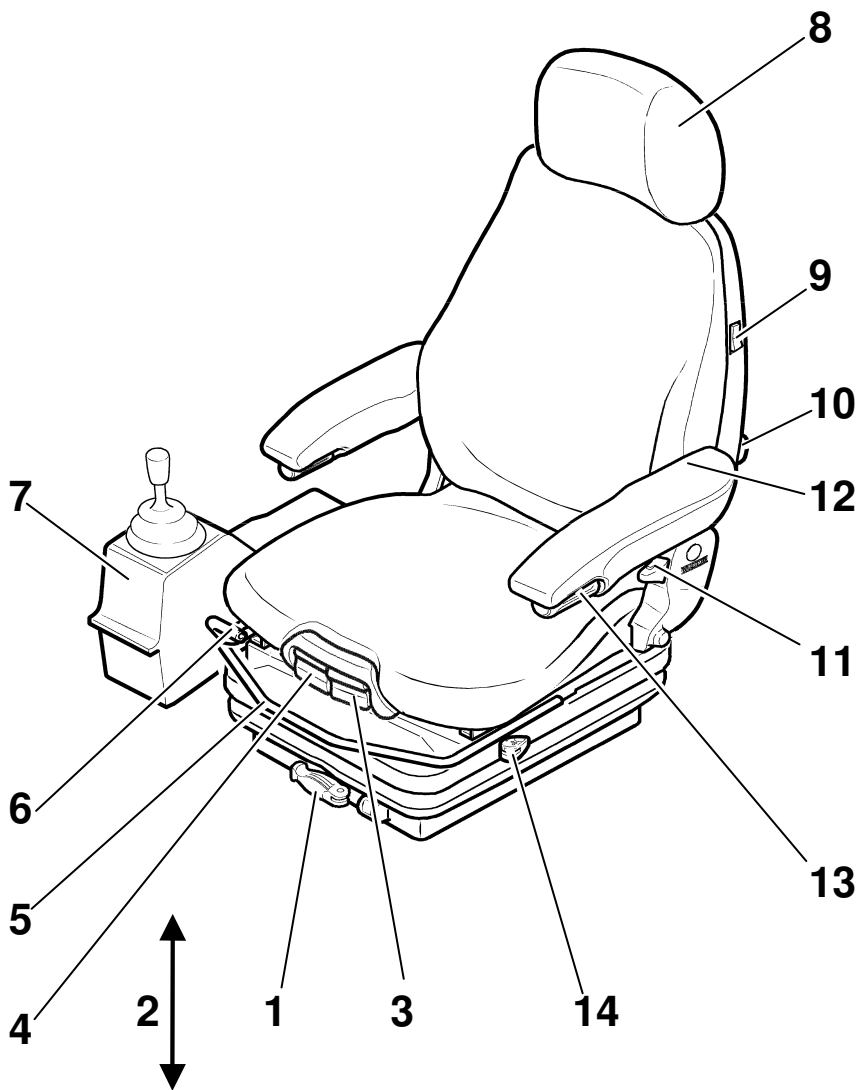

Contents

General instructions	20
Safety instructions.....	20
Guarantee and liability	22
Seat functions and operation	23
1 Weight adjustment.....	23
2 Height adjustment.....	23
3 Seat pan angle adjustment *.....	23
4 Seat depth adjustment *	24
5 Fore/aft adjustment with control carrier equipment *	24
6 Fore/aft adjustment without control carrier equipment	24
7 Control carrier * ***	25
8 Headrest * **	25
9 Seat heater *	25
10 Lumbar support *	26
11 Backrest adjustment.....	26
12 Armrests *	26
13 Armrest adjustment *	27
14 Fore/aft isolator *	27
Maintenance	28

* if fitted ** optional extra *** depending on model

General instructions

- The operating instructions must be read in full before use.
- The operating instructions must be kept in the vehicle and always be at hand.
- The driver's seat may only be fitted, serviced and repaired by specialist personnel. The respective national regulations and the vehicle manufacturer's fitting instructions must be observed.
The national fitting regulations can be obtained from **GRAMMER** AG or from agencies of the company, or from the vehicle manufacturer.
- A correctly functioning and individually adjusted driver's seat is essential to your health. Take adequate care of your seat and have it serviced regularly to ensure that it functions correctly.



The functional checks are to be carried out at least as regularly as vehicle services (see maintenance plan for vehicle).

- These operating instructions should always be kept with the driver's seat. If the seat is passed on to a third party, it must be accompanied by the relevant operating instructions.
- Subject to modifications serving engineering progress and deviations compared to the standard type seat arising therefrom.



Safety instructions

- Driver's seats that have been adjusted incorrectly have a smaller moving area. To prevent damage to the driver's back and to the seat, the seat must be adjusted for the driver's weight **before use** and **before every change of driver**.
- To prevent injury, **no objects should be placed within the moving area** of the driver's seat.
- **Before commissioning** of the driver's seat, possible **packaging material** has to be removed from the seat cushion and the backrest upholstery.
- To eliminate any risk of accident, the settings must be checked to ensure they are correctly engaged **before the vehicle is driven**.
- Adjustments must **not** be made **while driving**.
- **When the backrest cushion has been removed**, the backrest frame must be supported, for example held in place, before the backrest adjuster is operated. If you fail to do so, there is a danger that the backrest frame may jerk forward and **cause injury**.

- **Any changes to the series standard of the seat** (for example fitting parts which are not original **GRAMMER** parts) may impair the safety standard to which it has been tested. **Functions may be impaired**, threatening your **safety**. For this reason, **any change in design of the seat** must be approved by **GRAMMER AG**.
- During the removal and installation of the driver's seat, the corresponding instructions by the specific vehicle manufacturer must be strictly observed!
- Do not hold onto the covers for lifting the driver's seats. If you do so anyway, there is an **increased risk of injury due to loosening or breaking covers**.
- Before you remove the driver's seat, disconnect all plug-in connections between the seat and the vehicle supply network. When you replace the plug-in connectors, make sure they are tight (dust, water).
- Seatbelts are fitted or can be retrofitted to the driver's seat. Seatbelts **may only be fitted on the approval of the vehicle manufacturer**, as they increase the load in the seat mounting area.
Seatbelts must be fitted in accordance with specific national regulations and guidelines, and must be approved by **GRAMMER AG**.
- Seatbelts must be fastened **before driving**.
The seatbelts must be replaced after an accident.
Where seatbelts are fitted to the driver's seat, the **seat** and **seat mounting** must be checked **additionally** by specialist personnel after an accident has occurred.
- Fasteners must be **checked regularly for tight seat**. If the seat wobbles, there may be loose bolts or other faults.
- If you notice that the seat does not function correctly (for example a defective suspension of the driver's seat; improper curvature of the lumbar support or damaged bellows), **contact a specialist workshop immediately** to arrange for repairs to be carried out. If you fail to do so, your health may be affected and the **risk of accident increased**.
- Before the vehicle is used, switches that might be in the seat (for shutting down mechanical equipment when the driver leaves his/her seat) must be checked for **proper function**.
If malfunctions are detected, the vehicle must not be driven.
– **INCREASED RISK OF ACCIDENT** –
- **Loads must not be placed on seats** (e.g. with a built-in switch) except for the driver's weight during normal use, as the vehicle may otherwise start to move by itself.
– **INCREASED RISK OF ACCIDENT** –
If you take off the weight from the seat while driving, this will cause the vehicle to stop.
- Do not indent the bellows while there is load on the driver's seat.
– **RISK OF CRUSHING** –
- Make sure that the **interior of the driver's seat** remains free of **foreign particles** or **liquids**.

Safety instructions

- The driver's seat is **not watertight** and must be protected against splashes of water!
- Any conversion or refitting work on a **GRAMMER AG** driver's seat must be performed exclusively in **authorized workshops** by **trained** or **suitably qualified personnel** and in adherence with the applicable operating, maintenance and installation instructions and in compliance with all relevant national regulations. **Improper installation and assembly** bear the risk of **bodily injury** or **property damage** and the proper function of the driver's seat or mounted parts can no longer be guaranteed.
- The driver's seat is **free of maintenance**. Worn parts such as rollers, shock absorbers and the fixation must be checked from time to time.
- **Before driving**, you must check if all seat settings selected guarantee a **safe operation** of the vehicle.

Guarantee and liability

- **GRAMMER AG** does not disclaim any guarantee or liability for damage resulting from incorrect assembly, use or repair of the seats.
- Further details on the guarantee granted by **GRAMMER AG** are stated in your contractual documents (see invoice or delivery note). Guarantee claims against **GRAMMER AG** beyond the guarantee obligations described there are excluded.

Seat functions and operation

Weight adjustment

The seat is adjusted for the driver's weight by turning the weight adjuster lever with the seat empty. The set weight can be read from the indicator.

☞ To prevent damage to the health, the setting for the driver's weight must be checked and adjusted as necessary before the vehicle is driven.

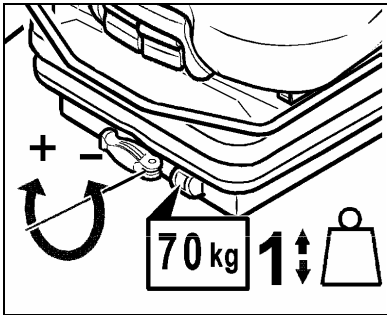

Height adjustment

The seat height can be adjusted with several settings.

Raise the driver seat to the required height until it audibly latches into place. When the seat is raised above the highest setting (endstop) it drops back down to the lowest position.

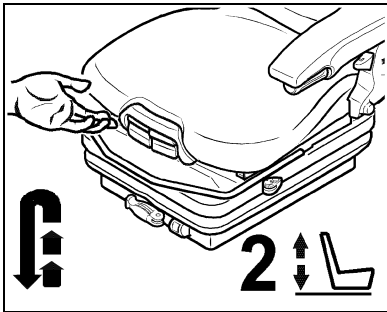

Seat pan angle adjustment *

The angle of the seat pan can be individually adjusted.

To adjust the angle of the seat pan, pull the left handle upwards. By exerting pressure on or off the front or rear part of the seat pan it can be moved to the desired angle position.

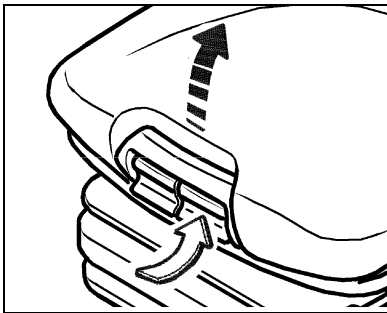

* if fitted

Seat functions and operation

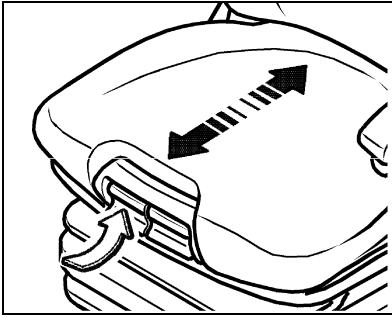

Seat depth adjustment *

The depth of the seat pan can be individually adjusted.

To adjust the depth of the seat cushion, pull the right handle upwards. By moving the seat cushion backwards or forwards the desired seating position can be reached.

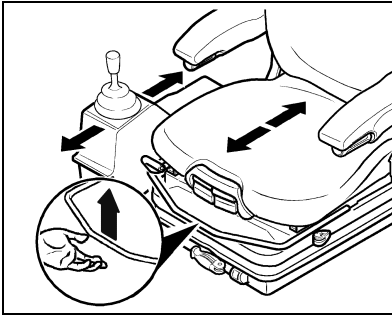

Fore/aft adjustment with control carrier equipment *

The fore/aft adjustment for the driver's seat and the control carrier equipment is released by lifting the locking lever.



WARNING! Risk of accident!
Do not operate the locking lever while driving.

☞ After the adjustment, the locking lever must latch into the desired position with an audible click. It should not be possible to move the driver's seat into another position after it has been locked.

☞ Do not lift the locking lever with your leg or calf.

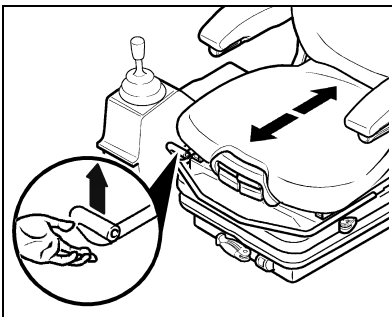

Fore/aft adjustment without control carrier equipment

The fore/aft adjustment for the driver's seat is released by lifting the locking lever.



WARNING! Risk of accident!
Do not operate the locking lever while driving.

☞ After the adjustment, the locking lever must latch into the desired position with an audible click. It should not be possible to move the driver's seat into another position after it has been locked.

* if fitted

Seat functions and operation

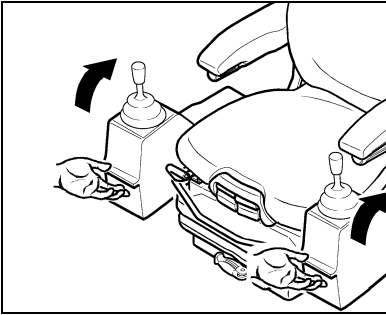

Control carrier * ***

To improve getting in and out of the seat the left or right box can be tilt up.

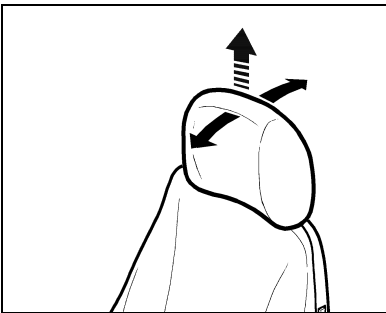

Headrest * **

The headrest can be individually adjusted for height by pulling it upwards or pushing it downwards over the various locking increments up to the end stop.

The angle of the headrest can also be adjusted individually by pushing forwards or rearwards.

To remove the headrest, pull it upwards over the end stop.

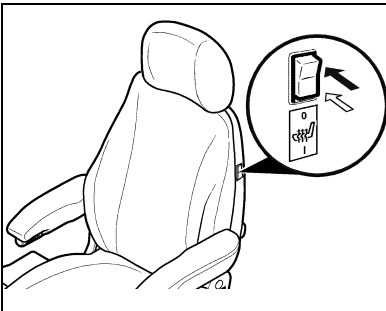

Seat heater *

The seat heater is turned on by pressing the switch.

* if fitted ** optional extra *** depending on model

Seat functions and operation

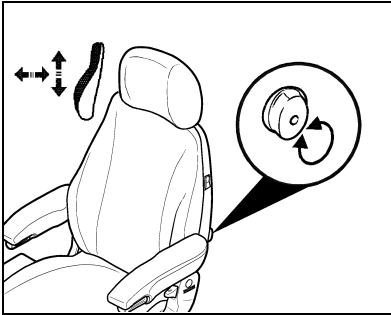

Lumbar support *

By turning the adjustment knob to the left or right, both the height and curvature of the backrest cushion can be individually adjusted.

This increases both the seating comfort and the performance of the driver

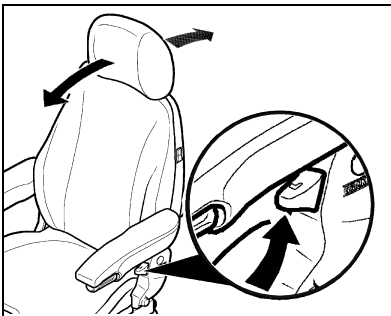

Backrest adjustment

Pull up the locking lever to release the backrest catch. When releasing the backrest catch, do not apply load to the backrest by pressing against it.

By exerting pressure on or off the front or rear part of the seat pan it can be moved to the desired position. Release the locking lever to lock the backrest.

☞ It should not be possible to move the backrest into another position after it has been locked.

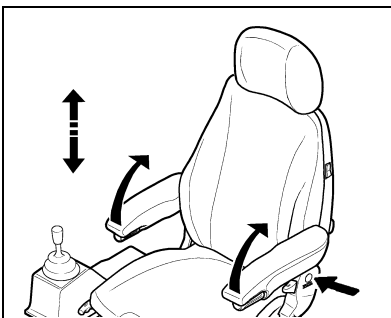

Armrests *

The armrests can be folded up if required and the height individually adjusted.

To adjust the armrests for height, separate the round cap (see arrow) from the cover.

Loosen the hexagon nut (size 13mm) and adjust the armrest to the desired position and tighten the nut again.

* if fitted

Seat functions and operation

Armrest adjustment *

The inclination of the armrests can be modified by turning the adjustment knob (arrow)

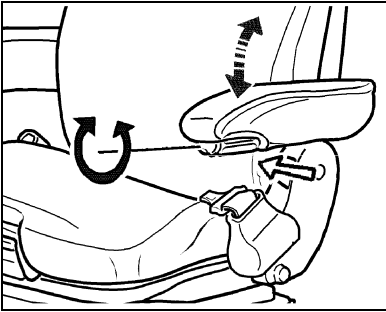

Fore/aft isolator *

Under certain driving conditions (for example with a trailer attached), it is useful to activate the fore/aft isolator. This means that shock impacts in the driving direction can be better absorbed by the driver seat.

Position 1 = fore/aft isolator on
Position 2 = fore/aft isolator off

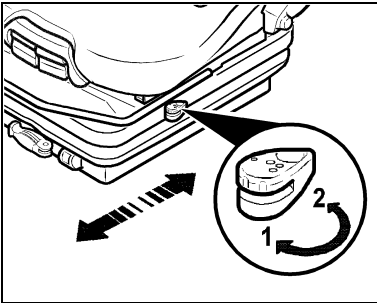

* if fitted

Maintenance

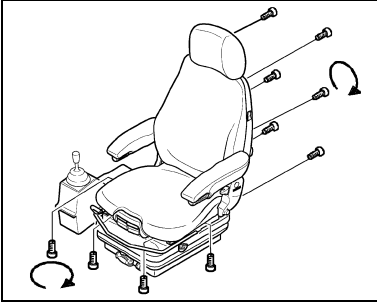

Dirt can impair the function of the seat,
So make sure you keep your seat clean.

Upholstery does not need to be removed from
the seat frame for cleaning.



Caution: take care with the backrest - it may jerk forward and cause injury!
When cleaning the backrest cushion, the backrest must be held in place when operating the backrest lever.

ATTENTION: Do not clean the seat with a pressure washer!

During cleaning the upholstery should not be soaked through.

Use standard commercially available **upholstery or plastics cleaning agent. Test first for compatibility** on a small, concealed area.

