

# KOENIG COMFORT HEAVY DUTY SEATS

J.R. MERRITT<sup>®</sup>  
CONTROLS 

Designed around function, comfort, and quality, the Koenig Comfort seat offers a highly robust seating solution with premium materials and a range of features and adjustability.

## STANDARD FEATURES

- Premium leather or cloth upholstery
- U-cut or full seat cushion
- Full-body contoured design for optimum operator support
- Upper and lower lumbar support and adjustment
- Adjustable headrest



--DESIGNED  
FOR COMFORT



--HIGHLY  
ADJUSTABLE



--BUILT FOR  
PERFORMANCE

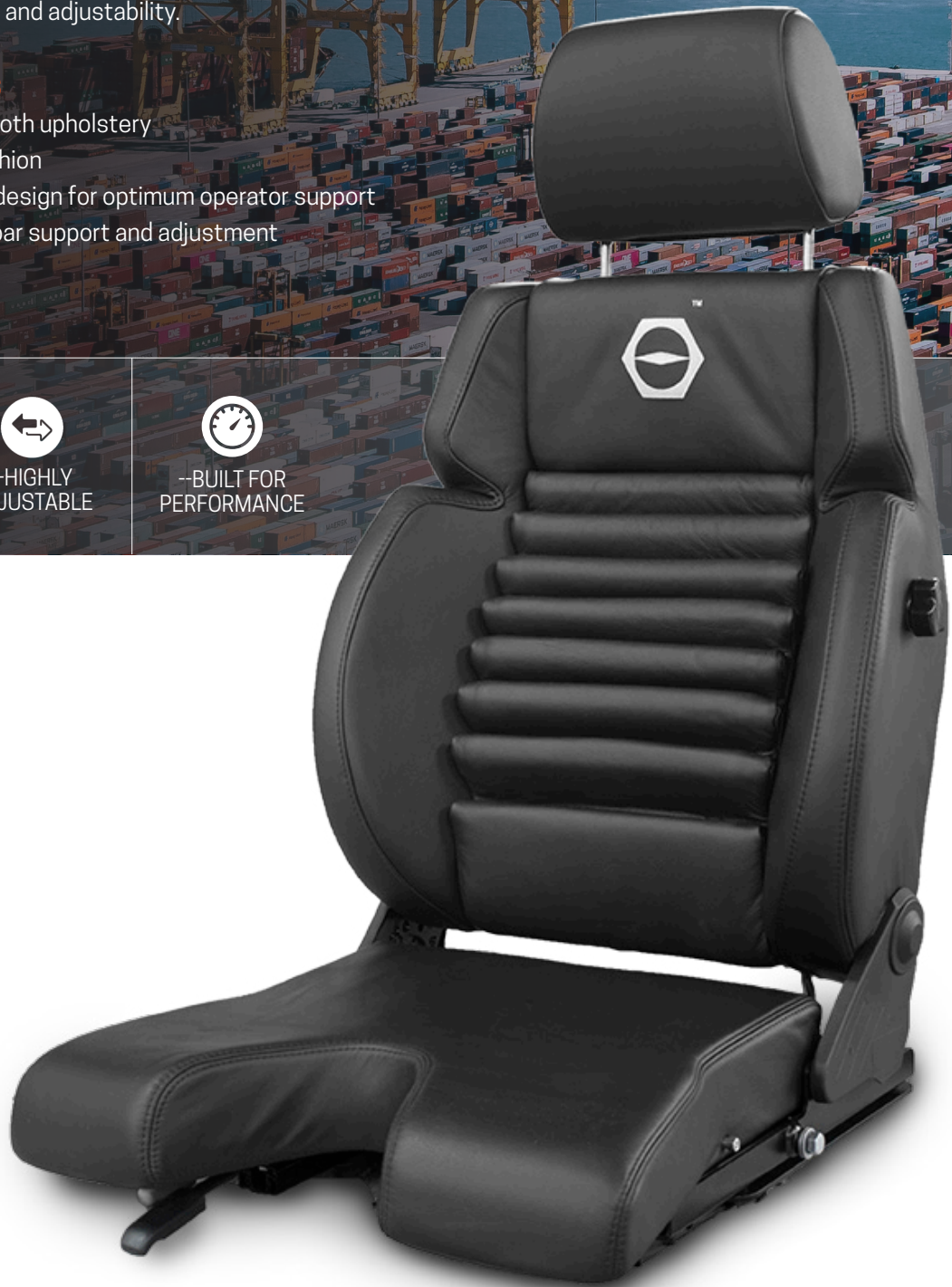

## ADJUSTMENT FEATURES

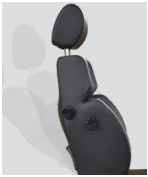

### BACKREST RECLINE & COLLAPSE

Features electric or mechanical 80° backrest recline & the ability to fold forward for transportation and service.



### HORIZONTAL SEAT SLIDE

8" of horizontal forward & backward seat movement independent of the system's consoles.



### LUMBAR SUPPORT

Mechanically controlled lower & upper lumbar support\* that adjusts the curvature & height of the backrest cushion.



### SEAT CUSHION DEPTH

Adjusts forward & backward.





### BAFFLES

Incorporated into backrest to allow for increased airflow. \*Exclusive to leather Koenig seat model.

### ATTENTION TO DETAIL

Incorporated into backrest to allow for increased airflow. \*Exclusive to leather Koenig seat model.



UPHOLSTERY TYPE & FEATURES		
	<p><b>LEATHER</b> Full leather with baffles</p> 	<p><b>CLOTH</b> Cloth with vinyl trim</p> 
LOWER LUMBAR ADJUSTMENT	✓	✓
UPPER LUMBAR ADJUSTMENT	✓	✗
BACKREST RECLINE	Motorized	Mechanical
ADJUSTABLE SIDE SUPPORT	✓	✗
BAFFLES / BACK RIDGES	✓	✗
HEADREST	✓	✓
OPERATOR PRESENCE SWITCH	✓	✗
HEATED SEAT	✓	✗

SEAT CUSHION TYPE	
<p><b>U-CUT</b> Increased line of site for applications where operator is required to look down</p> 	<p><b>FULL</b> Offers optimal operator comfort for typical applications</p> 

## DIMENSIONS

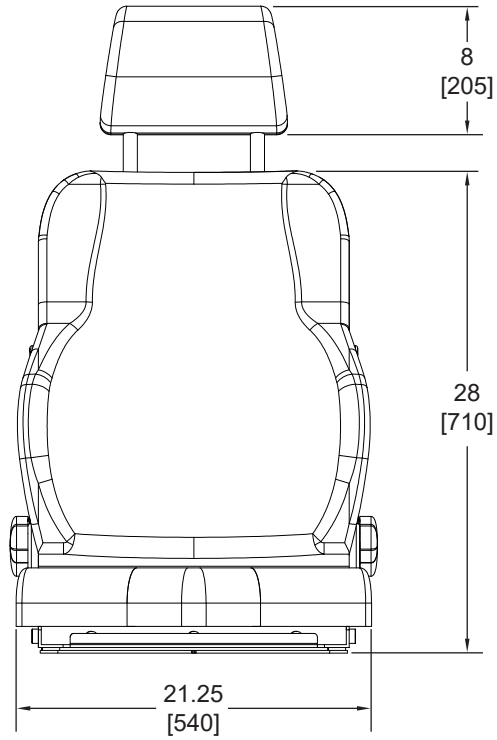

All dimensions in inches [mm] and are subject to change.