

VNSO MILL DUTY JOYSTICK CONTROLLER INSTALLATION INSTRUCTIONS & SERVICE BULLETIN

Description

The Type VNSO Mill Duty Masterswitches and Joysticks are available with the switches and potentiometers mounted so they extend horizontally or vertically from the Joystick body. Designs are configured to accommodate your specific space requirements.

The VNSO controller provides a step or stepless output for controlling the operation of heavy equipment and machinery.

Installation

The VNSO controller requires a 5 hole mounting pattern (see panel hole detail). It is not necessary to remove the operating knob or boot to install the VNSO controller.

Access to the controller should be comfortable and unobstructed. Care should be taken in console and cab design to **AVOID LOCATIONS WHERE:**

- Inadvertent operation is possible
- Operator is able to apply an excessive amount of force to the control lever.
- Control handle could be used as a means of supporting entrance and exit from the cab area
- Hand and knuckle clearance is limited.

PANEL HOLE DETAIL

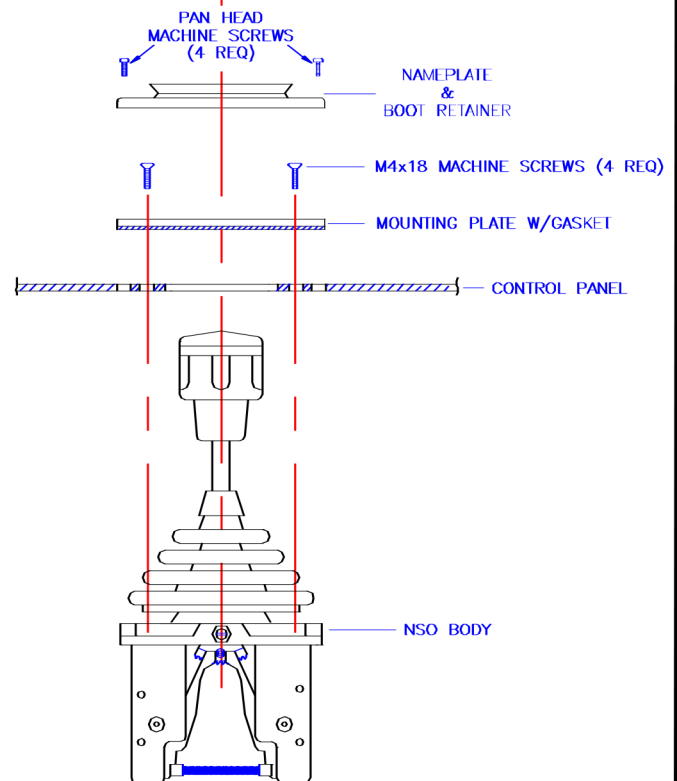
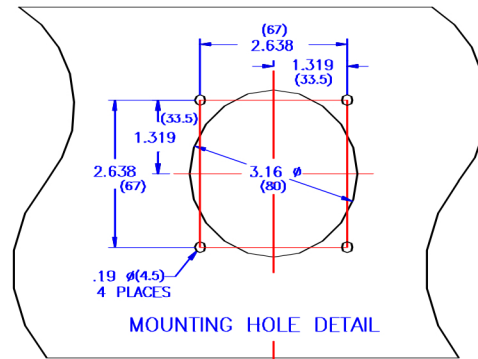

VNSO JOYSTICK



VNSO BASIC JOYSTICK

VNSO MILL DUTY JOYSTICK

CONTROLLER INSTALLATION INSTRUCTIONS & SERVICE BULLETIN



IMPORTANT:
DISCONNECT ALL POWER
PRIOR TO SERVICING CONTROLLER

Service

Periodic lubrication is recommended. A light grease should be applied to active components, such as spring return arms, yokes, gear drives and detent rollers.

Inspect for torn or damaged boots and replace them immediately.

Check assembly and mounting bolts for tightness.



Immediately report any abnormal operation characteristics of the controller to the proper authority. **DO NOT** continue to operate the equipment until the problem is resolved.

Wiring

The Type (V)NSO contacts utilize a saddle clamp type terminal. It is recommended when using bare copper wire that all terminal connections are re-tightened after a short interval to "coldflow" the conductor. Cold flowing the copper through re-tightening will insure a non-resistive connection.

Proportional Control

Potentiometers, Rotary Inductive Transformers, Encoders, Rheostats, etc. are field replaceable but may require calibration and alignment by a field service technician. Before operating, the device should be tested by an authorized technician for proper alignment and calibration.

Disclaimer

Joysticks are supplied with deadman spring return of handles to neutral. For safety reasons, electronic deadman equipment control is recommended for applications with maintained handle action. (Consult factory).

The customer is responsible for meeting OSHA compliance of deadman safety devices, providing operator safety and proper equipment use training, and for maintaining the equipment and controls in a safe working condition. Customer agrees to indemnify and hold J.R. Merritt Controls, Inc. harmless and defend at its expense, all claims and suits asserted or brought against J.R. Merritt Controls, Inc. due to the absence, removal, tampering, improper installation or improper use of this equipment and associated deadman safety devices.

Contacts and Cams

Cam-operated contacts are field replaceable and can be removed by gripping contact box between thumb and forefinger and pulling up in direction of terminals. Reinstall with terminals facing in proper directions by pressing box into locking nest (See Fig. 1). If contacts are to be cleaned, it is recommended that a low residue spray contact cleaner be used. (Never file or sand the contact tips).

NOTE: For low voltage dry circuit applications, gold contacts are available

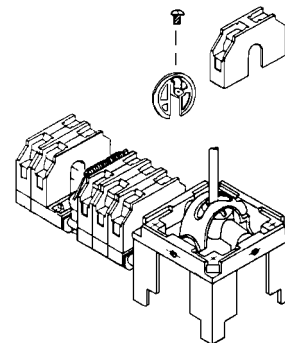

Fig. 1

Contact AC Ratings

AC continuous 16 amps @ 240 volts
AC resistive 8 amps @ 240 volts
AC inductive 6 amps @ 240 volts
1 H.P. 120 VAC 1 phase
2 H.P. 240 VAC 1 phase